

BIG INCH

“ OMEF Big Inch is a real game changer for vegetation clearing. Nothing more than strong and simple, the geometry and ram speak for themselves.

Eddie from UK

”





TREE SHEAR “BIG INCH”

Big Inch was born from the idea to **combine simplicity, efficiency and versatility in a single machine**, joined with an in-depth design and engineering study. The result is a worldwide success: designed to work on any type of wood, **“Big Inch” is able to grab, cut and hold the plant** at the same time.

The efficiency of the “Big Inch” shear is granted by **the quality of raw material used**. OMEF **relies only on wear resistant XAR steel** that makes the tree shear incredibly strong and robust and it ensures an outstanding performance even in the most extreme working conditions.

The integrated blade, which provides the **highest levels of resistance, hardness and toughness**, has a patented and unique profile in the world, making “Big Inch” capable of cutting down plants with a quick and neat cut.

Based on these elements, OMEF has developed the **largest range of tree shears on the market with six models available**. Big Inch can be fitted on operating machines starting from 2 t up to 50 t and it can be customized with several accessories able to increase the efficiency and productivity, offering the **best tailor made solution for all forestry professionals**.

PINZA CESOIA “BIG INCH”

Big Inch nasce dall’idea di **combinare semplicità, efficienza e versatilità in un’unica macchina**, unite a un approfondito studio progettuale ed ingegneristico. Il risultato è un successo mondiale: studiato per lavorare su tutti i tipi di legno, **“Big Inch” è in grado di afferrare, abbattere e trattenerne la pianta** contemporaneamente in totale sicurezza.

L’efficienza della pinza cesoia “Big Inch” è **garantita dalla qualità delle materie prime utilizzate**. Nel processo di produzione OMEF si affida soltanto **all’acciaio alto-resistenziale antiusura XAR** in grado di rendere la pinza cesoia incredibilmente solida e robusta e di assicurare le massime prestazioni anche nelle condizioni di lavoro più estreme.

La lama integrata, che fornisce **i più elevati livelli di resistenza, durezza e tenacità**, presenta un profilo brevettato ed unico al mondo, rendendo “Big Inch” capace di abbattere piante con un taglio rapido e netto.

Sulla base di questi elementi OMEF ha sviluppato **la linea di pinze cesoia più vasta sul mercato con sei modelli disponibili**. Big Inch è applicabile su macchine operatrici con peso da 2 t a 50 t e personalizzabile con svariati accessori che aumentano ulteriormente l’efficienza e la produttività offrendo così **la soluzione ideale per tutti i professionisti del settore forestale**.





1

Ganascia con braccio di leva maggiorato
Potenza di taglio aumentata. Abbattimento e trattenuta della pianta in un'unica azione

Extended lever arm
Increased cutting power. Felling and holding of the tree in a single action



4

Cilindro ad alte prestazioni
Controllo semplificato grazie all'utilizzo di una sola linea idraulica

High-performance cylinder
Simplified control thanks to the use of a single hydraulic line

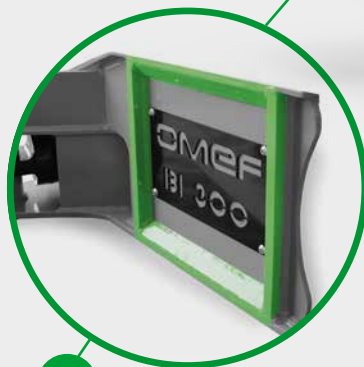

3

Struttura in XAR400
Compattezza, leggerezza, resistenza e sicurezza

Reinforced structure in XAR400
Compactness, lightness, resistance and safety

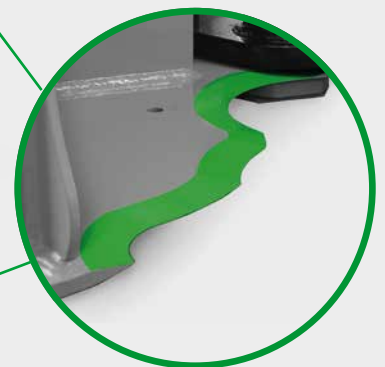

2

Lama integrata con 4 passaggi di saldatura
Profilo sagomato in XAR500, testato per un'efficienza di taglio maggiore su ogni tipologia di legno

Integrated blade with 4 welding steps
Shaped profile in XAR500, tested for greater cutting efficiency on all types of wood

	BI100	BI200	BI300	BI400	BI500	BI600
	1,5 - 3 tons	3 - 7 tons	8 - 14 tons	14 - 24 tons	23 - 30 tons	min. 30 tons
	140 Kg 310 lbs	230 Kg 507 lbs	420 Kg 925 lbs	845 Kg 1862 lbs	1810 Kg 3990 lbs	2400 Kg 5291 lbs
	40 mm 1,5"	50 mm 2"	60 mm 2,5"	120 mm 5"	200 mm 8"	270 mm 11"
	150 mm 6"	200 mm 8"	300 mm 12"	400/450 mm 16" / 18"	500/600 mm 20" / 24"	600/700 mm 23" / 27"
	180-220 bar 2610-3190 psi (min-max)	180-250 bar 2610-3625 psi (min-max)	180-280 bar 2610-4060 psi (min-max)	250-300 bar 3625-4350 psi (min-max)	300-350 bar 4350-5075 psi (min-max)	320-400 bar 4640-5800 psi (min-max)
	25-40 l/min 7-11 gal/min (min-max)	30-80 l/min 8-21 gal/min (min-max)	50-120 l/min 13-32 gal/min (min-max)	100-180 l/min 26-48 gal/min (min-max)	180-250 l/min 48-66 gal/min (min-max)	250-300 l/min 66-80 gal/min (min-max)
Larghezza Width	800 mm / 31"	890 mm / 35"	1115 mm / 44"	1455 mm / 57"	1640 mm / 65"	1965 mm / 77"
Lunghezza Length	775 mm / 30"	1010 mm / 39"	1240 mm / 49"	1500 mm / 59"	1860 mm / 73"	2057 mm / 81"
Altezza Height	420 mm / 16"	462 mm / 18"	552 mm / 22"	707 mm / 28"	892 mm / 35"	1021 mm / 40"

ACCESSORIES

ACCESSORI



SECOND GRAB / SECONDA PINZA



ROTATION 360° / ROTAZIONE 360°



RIPPER



BUNCHER / PINZARACCOGLITRICE



HOLDER / SUPPORTO



CRANE ADAPTER "OMEF SWING" / SISTEMA OSCILLANTE

TREE SHEAR PINZA CESCOIA

BI100



TREE SHEAR “BIG INCH” – BI100

The little of “BIG INCH” family, only apparently. Equipped with a 10 t of force cylinder, it **allows a neat and quick cut up to 150 mm (6”) diameter**, transforming your mini excavator from 1.5 to 3 t, into an efficient forestry machine.

PINZA CESCOIA “BIG INCH” – BI100

La più piccola della famiglia “BIG INCH”, ma solo all'apparenza. Equipaggiata con un cilindro da 10 t di forza, **permette un taglio netto e pulito fino a un diametro di 15 cm**, trasformando un “semplice” miniescavatore, da 1.5 a 3 t, in un'efficiente macchina forestale.



TECHNICAL INFORMATION

CARATTERISTICHE TECNICHE



1,5 - 3 tons



140 Kg / 310 lbs



40 mm / 1,5"



150 mm / 6"



180 - 220 bar
2610 - 3190 psi
(min-max)



25 - 40 l/min
7 - 11 gpm
(min-max)

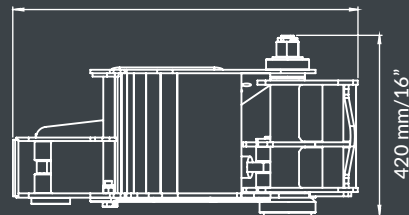
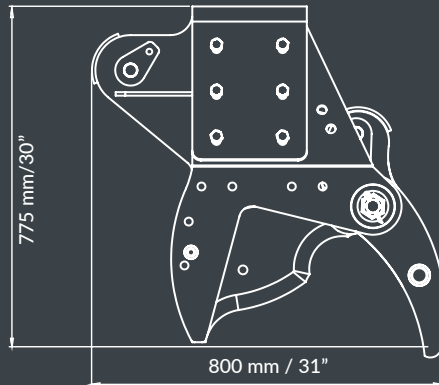

TREE SHEAR PINZA CESCOIA

BI200



TREE SHEAR “BIG INCH” – BI200

Compact, versatile and robust. Suitable for operating machines from 3 to 7 t, BI200 is the proper model for tree felling up to 200 mm (8”) diameter.

PINZA CESCOIA “BIG INCH” – BI200

Compatta, maneggevole e robusta. Applicabile su macchine operatrici da 3 a 7 t, BI200 è il modello ideale per abbattimenti fino a 20 cm di diametro.



TECHNICAL INFORMATION

CARATTERISTICHE TECNICHE

	3 - 7 tons
	230 Kg / 507 lbs
	50 mm / 2"
	200 mm / 8"
	180 - 250 bar 2610 - 3625 psi (min-max)
	30 - 80 l/min 8 - 21 gpm (min-max)

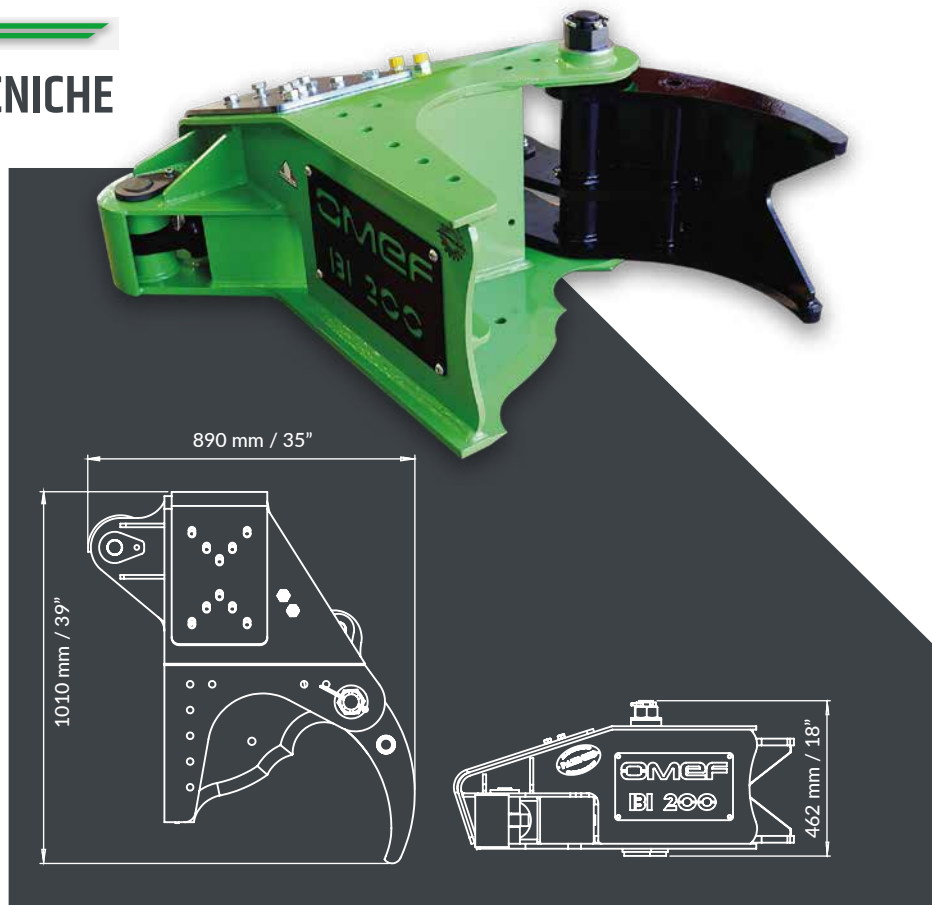

Compose your OMEF TREE SHEAR
Crea la tua pinza cesoia OMEF

ACCESSORIES

ACCESSORI



80 kg
175 lbs

BUNCHER: created and designed to collect small trunks together increasing the tree shear efficiency.

PINZARACCOGLITRICE: ideata per la raccolta contemporanea di piccoli tronchi aumentando la produttività della cesoia.



300 kg
660 lbs

360° ROTATION / ROTAZIONE 360°



SISTEMA OSCILLANTE
"OMEF SWING" /
CRANE ADAPTER
"OMEF SWING"

TREE SHEAR PINZA CESCOIA

BI300



TREE SHEAR “BIG INCH” – BI300

The **most popular unit of the range**. Suitable for medium-size operating machines, between 8 – 14 t. The performance allows high productivity and a cutting capacity up to 300 mm (12”) diameter. Equipped with a 33 t cylinder of force.

PINZA CESCOIA “BIG INCH” – BI300

La pinza cesoia **più popolare e venduta della serie**, ideale per l’applicazione su macchine operatrici di taglia media comprese tra le 8 e le 14 t. Le elevate prestazioni permettono un’alta produttività e una capacità di taglio fino a 30 cm di diametro.



TECHNICAL INFORMATION

CARATTERISTICHE TECNICHE

	8 - 14 tons
	420 Kg / 925 lbs
	60 mm / 2,5"
	300 mm / 12"
	180 - 280 bar 2610 - 4060 psi (min-max)
	50 - 120 l/min 13 - 32 gpm (min-max)

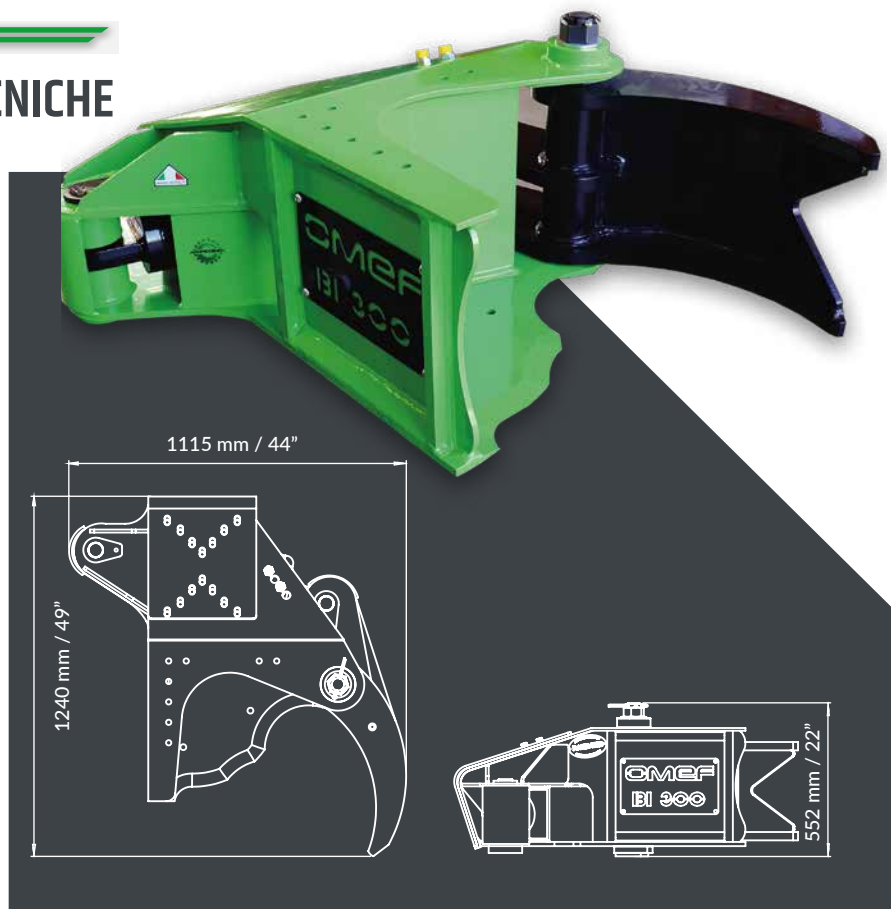

Compose your OMEF TREE SHEAR
Crea la tua pinza cesoia OMEF

ACCESSORIES

ACCESSORI



120 kg
265 lbs

BUNCHER: created and designed to collect small trunks together increasing the tree shear efficiency.

PINZA RACCOGLITRICE: ideata per la raccolta contemporanea di piccoli tronchi aumentando la produttività della cesoia.



360° ROTATION / ROTAZIONE 360°

350 kg
770 lbs



RIPPER

185 kg
410 lbs

TREE SHEAR PINZA CESCOIA

BI400



TREE SHEAR “BIG INCH” – BI400

Big unit, like the performance that it guarantees: cylinder with 70 t of force and cutting capacity over 400 mm (16”) diameter; BI400 fits to machines with operating weights from 14 to 24 t.

PINZA CESCOIA “BIG INCH” – BI400

La più piccola tra le “grandi” della famiglia, ma **dalle ottime prestazioni**: cilindro da 70 t di forza, abbattimenti che superano i 40 cm di diametro, il tutto applicabile su macchine con peso operativo da 14 a 24 t.



TECHNICAL INFORMATION

CARATTERISTICHE TECNICHE

	14 - 24 tons
	845 Kg / 1862 lbs
	120 mm / 5"
	400 mm / 450 mm 16" / 18"
	250 - 300 bar 3625 - 4350 psi (min-max)
	100 - 180 l/min 26 - 48 gpm (min-max)

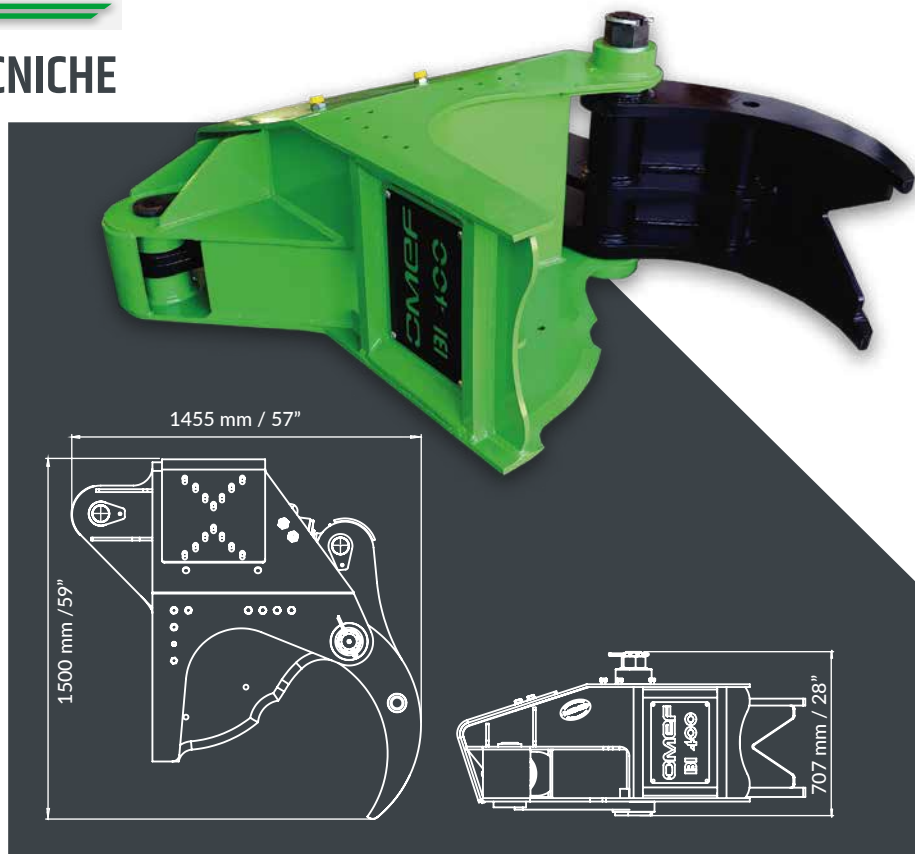

Compose your OMEF TREE SHEAR - Crea la tua pinza cesoia OMEF ACCESSORIES

ACCESSORI



KG 300 kg
660 lbs

GRAB ARM: designed for a better control during the cutting and handling phase of the tree.

SECONDA PINZA: ideata per un maggiore controllo durante la fase di taglio e di movimentazione della pianta.



KG 215 kg
475 lbs

BUNCHER: created and designed to collect small trunks together increasing the tree shear efficiency.

PINZA RACCOGLITRICE: ideata per la raccolta contemporanea di piccoli tronchi aumentando la produttività della cesoia.



KG 500 kg
1100 lbs

**360° ROTATION /
ROTAZIONE 360°**

KG 230 kg
510 lbs

RIPPER



KG 145 kg
320 lbs

HOLDER: designed for a better control during the handling phase of the tree.



SUPPORTO: ideato per maggior controllo durante la fase di movimentazione della pianta.

TREE SHEAR PINZA CESCOIA

BI500



TREE SHEAR “BIG INCH” – BI500

BI500 is **the real game changer for big projects**. Developed for excavators from 23 to 30 t, with 110 t cylinder of force, BI500 is able to provide a 600 mm (24”) cutting diameter.







PINZA CESCOIA “BIG INCH” – BI500

BI500 è **il punto di svolta per grandi abbattimenti**. Sviluppata per escavatori da 23 a 30 t, con cilindro da 110 t di forza, la macchina è in grado di eseguire un taglio fino a 60 cm di diametro.



TECHNICAL INFORMATION

CARATTERISTICHE TECNICHE

	23 - 30 tons
	1810 Kg / 3990 lbs
	200 mm / 8"
	500 mm / 600 mm 20" / 24"
	300 - 350 bar 4350 - 5075 psi (min-max)
	180 - 250 l/min 48 - 66 gpm (min-max)

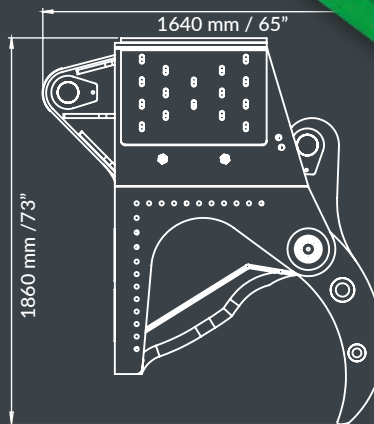

Compose your OMEF TREE SHEAR Crea la tua pinza cesoia OMEF

ACCESSORIES

ACCESSORI



640 kg
1410 lbs

GRAB ARM : designed for a better control during the cutting and handling phase of the tree.

SECONDA PINZA : ideata per un maggiore controllo durante la fase di taglio e di movimentazione della pianta.

**TREE SHEAR
PINZA CESCOIA**

BI600



TREE SHEAR "BIG INCH" – BI600

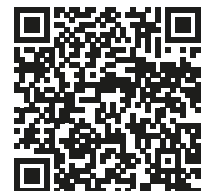

OMEF latest addition. **2400 kg of pure power**; for excavators starting from 30 t of operating weight. Numbers speak for themselves: **more than 700 mm (27") of cutting capacity** and 140 t of force coming from the huge cylinder.

PINZA CESCOIA "BIG INCH" – BI600

L'ultima arrivata in casa OMEF. **2400 kg di pura potenza**, per escavatori a partire da 30 t di peso operativo. I numeri parlano chiaro: **oltre 70 cm di diametro di taglio** e una forza sviluppata dal cilindro di 140 t.



TECHNICAL INFORMATION

CARATTERISTICHE TECNICHE



min. 30 tons



2400 Kg / 5291 lbs



270 mm / 11"



600 mm / 700 mm
23" / 27"



320 - 400 bar
4640 - 5800 psi
(min-max)



250 - 300 l/min
66 - 80 gpm
(min-max)

